

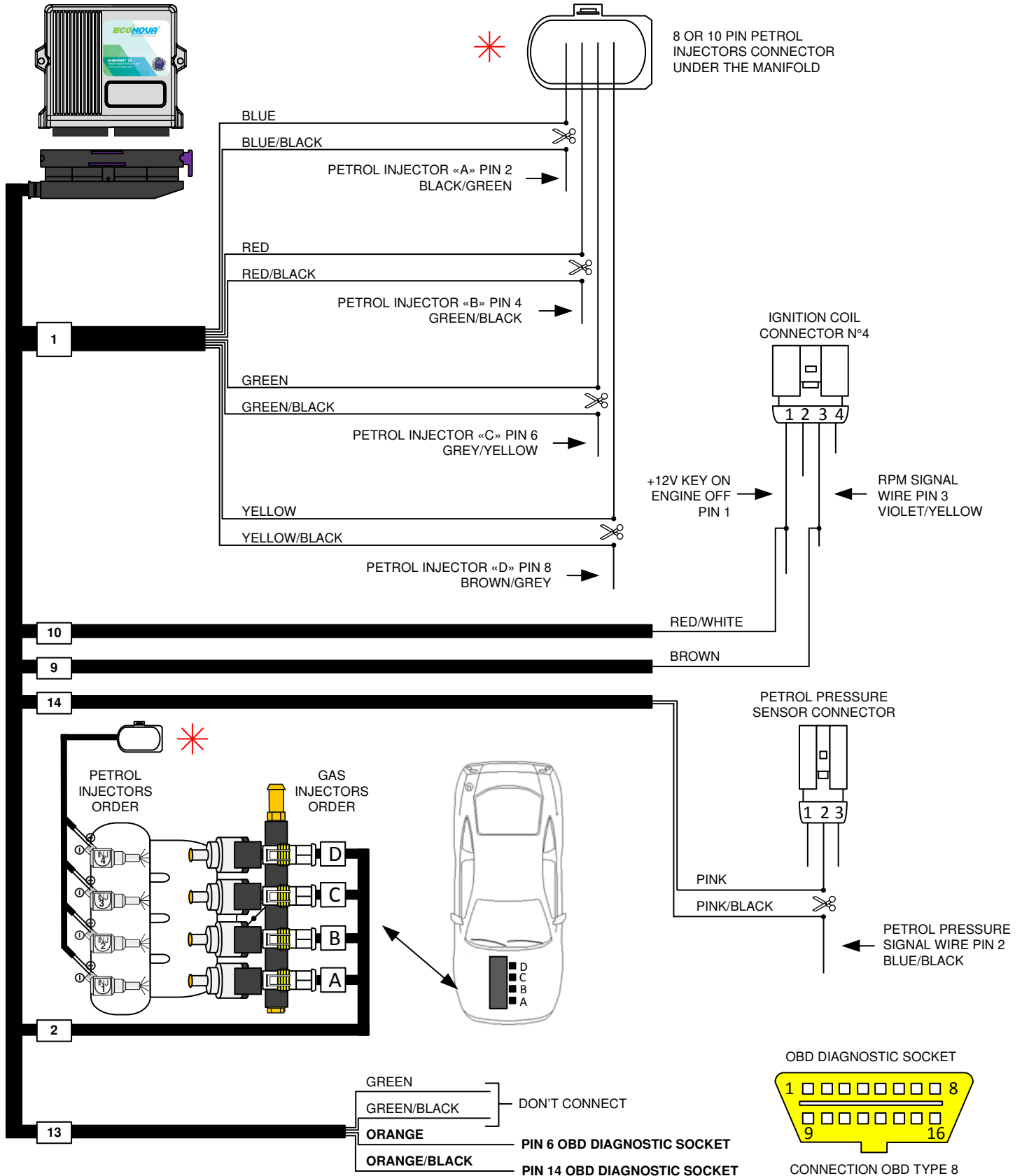

## [BPJ] Audi 2.0 Tfsi 125 Kw Bosch Motronic Med 9.1 MY2004



**[BPJ] Audi 2.0 Tfsi 125 Kw Bosch Motronic Med 9.1 MY2004**



IGNITION COIL  
CONNECTOR N°4

PETROL PRESSURE  
SENSOR CONNECTOR

8 ( OR 10) PIN  
CONNECTOR POSITION



8 (OR 10) PIN PETROL  
INJECTORS CONNECTOR



**MANIFOLD APPLICATION**

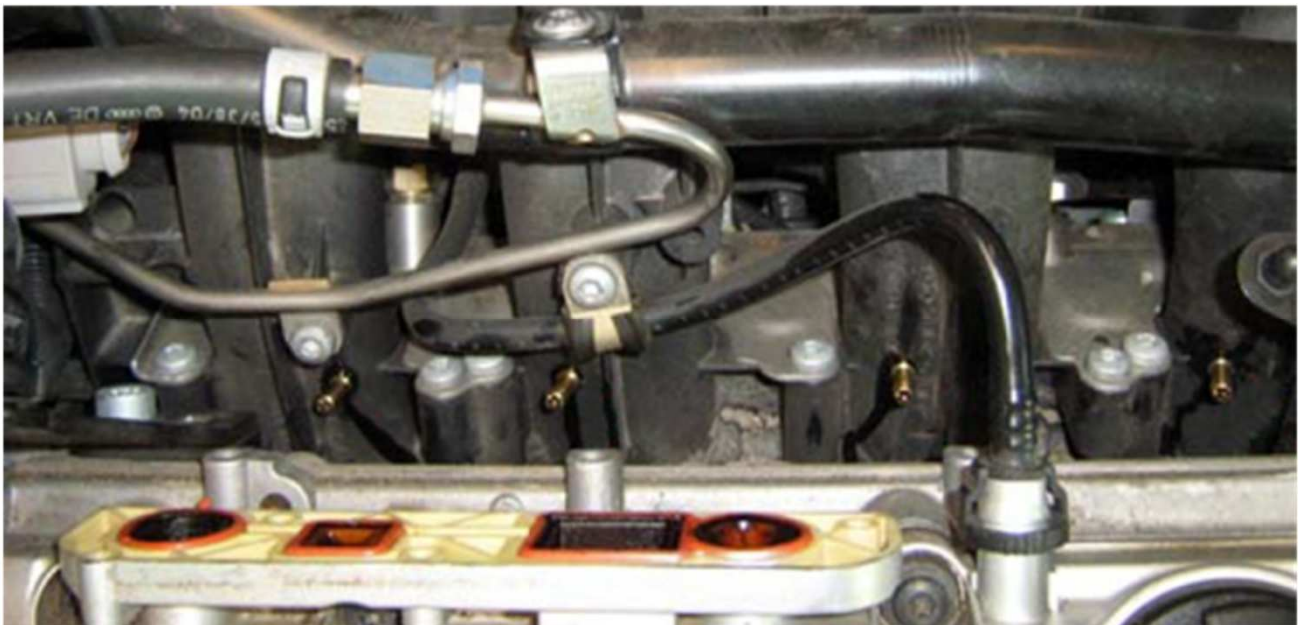

## [BPJ] Audi 2.0 Tfsi 125 Kw Bosch Motronic Med 9.1 MY2004

INFO: -ECU AJ-500 ver. A  
 -RIDUTTORE 1.0 Bar  
 -INIETTORI HANA 1.9 (Ugelli con una tacca),  
**Controllare la mappa gas**

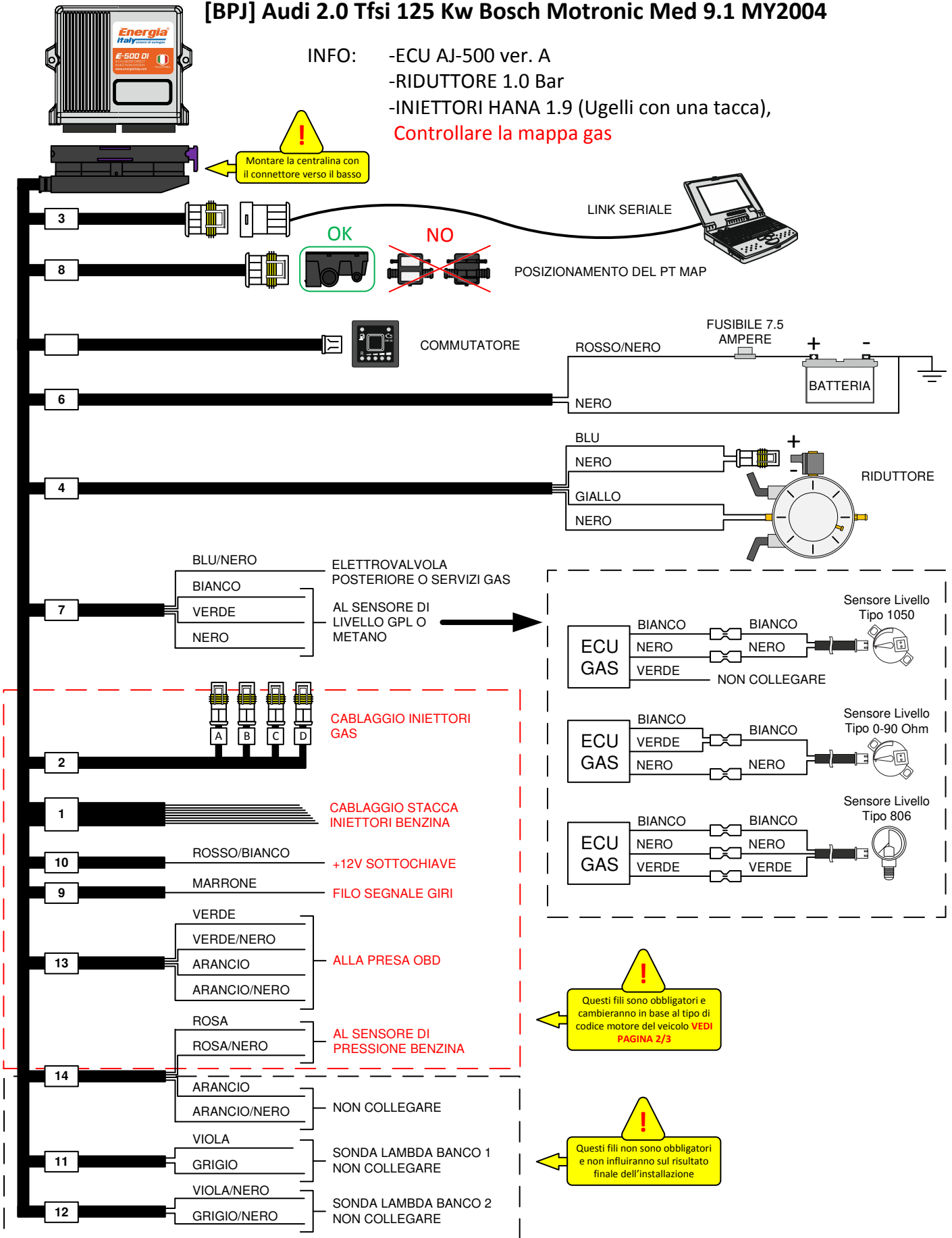

## [BPJ] Audi 2.0 Tfsi 125 Kw Bosch Motronic Med 9.1 MY2004

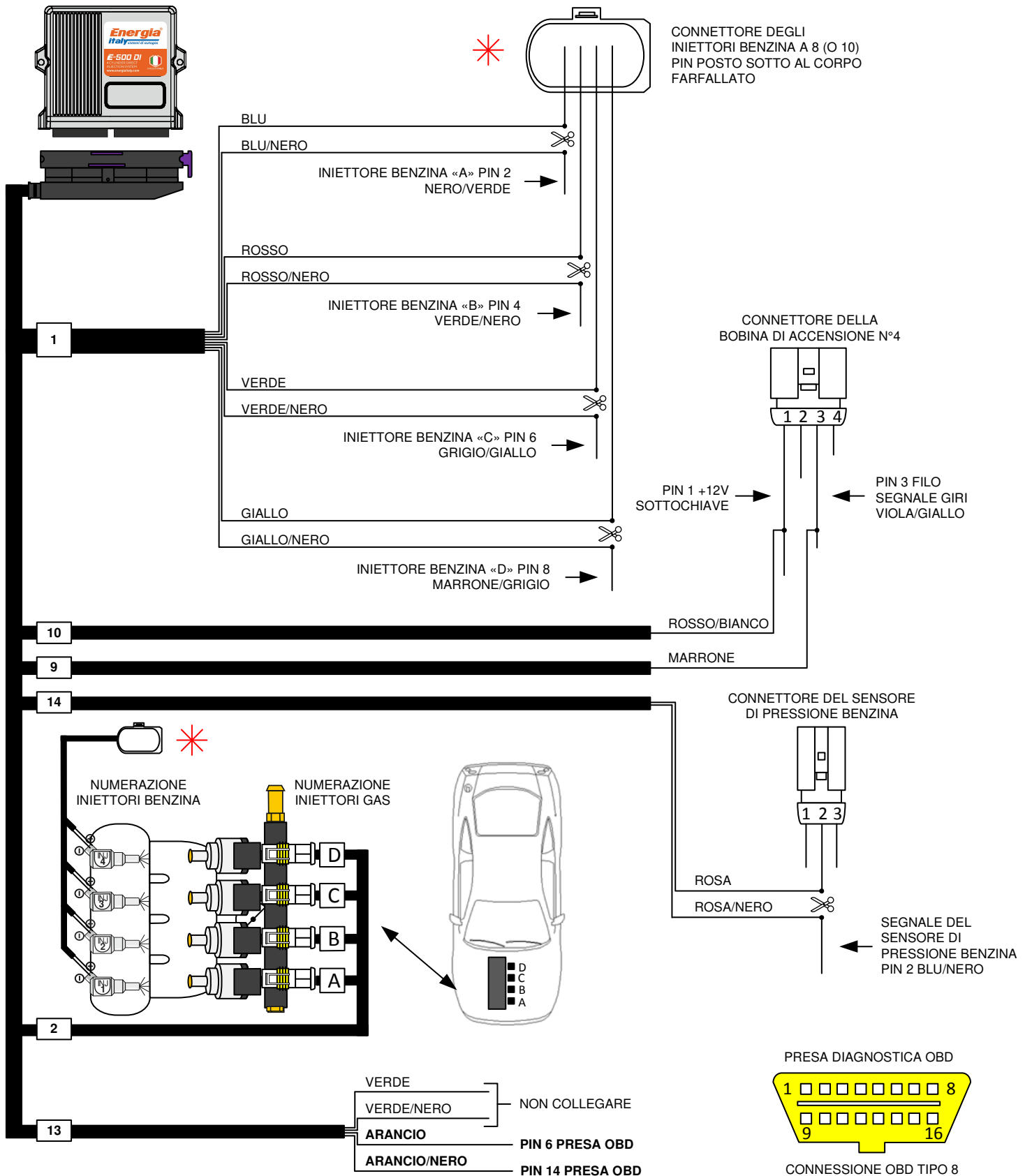



**[BPJ] Audi 2.0 Tfsi 125 Kw Bosch Motronic Med 9.1 MY2004**



BOBINA D'ACCENSIONE N°4

SENSORE PRESSIONE  
BENZINA

POSIZIONE DEL CONNETTORE AD  
8 (O 10) PIN



CONNETTORE A 8 (O 10) PIN



**APPLICAZIONE SUI COLLETTORI**

